

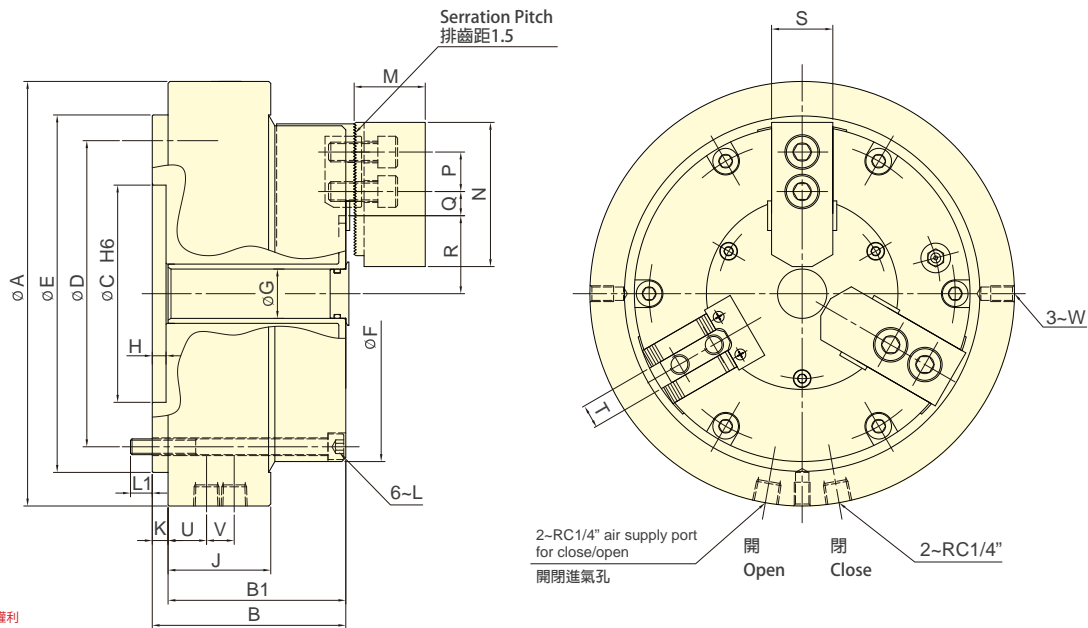

- 內建氣缸之薄型迴盤夾頭, 所佔空間小, 適合輕切削場合, 並可使用標準生爪或標準硬爪。
- 適用於分度盤上進行分度加工。
- 迷宮環防塵機構設計, 加工中切屑不易進入夾頭內。
- 摺動面均經硬化及精密研磨, 並直接潤滑。
- Rotary chuck with built-in pneumatic cylinder, compact design, suitable for light machining, compatible to standard soft jaw/hard jaw.
- Can be installed on a rotary table for indexing machining.
- Sealed against dust and cutting chips.
- Matching surfaces of all parts hardened, ground and lubricated directly.
- 注意: 由於固定配氣環與夾頭本體之間旋轉摩擦, 第四軸分度盤的旋轉扭矩必須高於下表所示。
- Note: To overcome friction force between distributor ring and chuck body, the rotating torque of rotary table must be high than the requirement shown in the table.



保留規格修改的權利
Subject to technical changes

技術規格 SPECIFICATIONS

型號 Model	爪行程 (直徑) Jaw stroke (Dia.)	夾持直徑 Chucking Dia.		最大夾持力 氣壓(使用壓力6.0 kgf/cm ²) Max. clamping force Pneumatic (at 6.0kgf/cm ²)	最大使用壓力 Max. pressure	最高轉速 Max. speed	旋轉扭矩 Max Rotation resistance torque	空氣消耗量 (使用壓力6.0 kgf/cm ²) Air consumption (at 6.0 kgf/cm ²)	重量 Weight
		最大 Max.	最小 Min.						
	mm	mm	mm	kN (kgf)	(kgf/cm ²)	(r.p.m.)	Nm	lit (kgf/cm ²)	kg
RAP-306	5.5	170	25	21.0(2141.4)	7	72	40	3.1	16.2
RAP-308	6.8	215	37	34.2(3487.4)	7	60	60	3.1	30.6
RAP-310	7	254	53	48.0(4894.7)	7	53	85	4.2	42.4

外型尺寸 DIMENSIONS

Model	A	B	B1	C (H6)	D	E	F	G	H	J	K
RAP-306	215	98	90	110	155	181	170	25	7	52	8
RAP-308	260	113	104	110	200	226	215	32	8	52	9
RAP-310	300	117	52	140	235	261	254	54	8	52	10

Model	L	L1	M	N	P	Q max.	Q min.	R max.	R min.	S	T	U	V	W
RAP-306	6-M8	11	36	73	20	10.75	6.25	47	44.25	31	12	19.5	14	3-M8
RAP-308	6-M8	16	37	95	25	13.25	8.75	57	53.6	35	14	19.5	14	3-M8
RAP-310	6-M8	14	42	110	30	23.25	12.75	64.5	61	40	16	19.5	14	3-M8